



ECM ECMCS Current Switch

ACI ECMCS split-core current switches are designed for use in electronically commutated motor (ECM) applications in which you are looking for status for a particular piece of equipment. ECMs have a unique operating profile that includes a small standby current when the motor is powered but not actively spinning compared to no current draw of traditional PSC motors.

The ECMCS switches do not require external power, since the power for the current switch is induced from the conductor being monitored. ACI's ECMCS switch has an adjustable trip level to set the desired trip level for proper motor status indication in most ECM applications. ACI offers a calibration tool that will help assist the installation process by implementing a visual indication of the state of the output switch to the installer.

The ECM current switch can be secured to the monitored cable using a cable tie and the integrated cable tie anchor feature of the housing. The ECMCS switch also comes with an attachable mounting foot that allows the unit to be mounted in any position using one Tek screw or snapped directly on a 35mm DIN rail.

Note: The ECM switch is not intended to monitor status in VFD motor applications.

Applications: Pump Status, Fan Status, Compressors, Air Handlers, Residential Furnaces, Motor Status

The ECMCS are covered by ACI's Five (5) Year Limited Warranty. The warranty can be found in the front of ACI's Sensors & Transmitters catalog, as well as on ACI's web site, workaci.com.

PRODUCT SPECIFICATIONS

Monitored Current Type:	AC Current
Maximum AC Voltage:	600 VAC
Operating Frequency Range:	50/60 Hz
Core Style:	Split-Core
Sensor Power:	Induced from the Monitored Conductor (Use Insulated Conductors only)
Amperage Range:	0 to 25 A
Insulation Class:	600 VAC
Trip Point Style Adjustable Trip Point Range:	Adjustable Trip Point 0.075 A to 0.50 A
Hysteresis:	10% of Trip Level Current, Typical
Contact Type:	Normally-Open "N/O"
Contact Rating:	100 mA Continuous @ 30 VAC/VDC
Contact "On" Resistance "Off" Resistance:	< 10 Ohms (when tripped) > 1 Meg Ohms (Open)
Response Time:	< 5 Seconds Typical
Aperture Size (Diameter) Wire Size:	0.20"(5.0mm) x 0.49"(12.5mm) Fits 10 AWG to 14 AWG THHN Insulated Wire
DIN Rail Size:	35 mm
Operating Temperature Range:	32°F to 140°F (0°C to 60°C)
Operating Humidity Range:	10 to 90%, non-condensing
Recommended Storage Temperature RH Range:	-40 to 158°F (-40 to 70°C) 10% to 90% RH, non-condensing
Enclosure Material Flammability Rating:	PC/ABS (Polycarbonate/ABS Blend) UL94-V0
Wiring Connections:	2 Position Screw Terminal Block (Not Polarity Sensitive)
Wire Size:	16 to 22 AWG (1.31 mm ² to 0.33 mm ²) Copper Wires Only
Terminal Block Torque Rating:	4.43 to 5.31 in-lbs. (0.5 to 0.6 Nm)
Minimum Mounting Distance:	1" (2.6 cm) between current switch & other magnetic devices (Relays, Contactors, Transformers)
Agency Approvals:	UL/CUL US Listed (UL 916) Energy Management Equipment (File # E334792), CE, UKCA, RoHS, WEEE, CAN ICES-3 / NMB-3
Product Weight:	0.14 lbs. (0.065 kg)
Product Dimensions (L x W x H):	1.93" (48.99 mm) x 1.31" (33.17 mm) x 2.18" (55.37 mm)

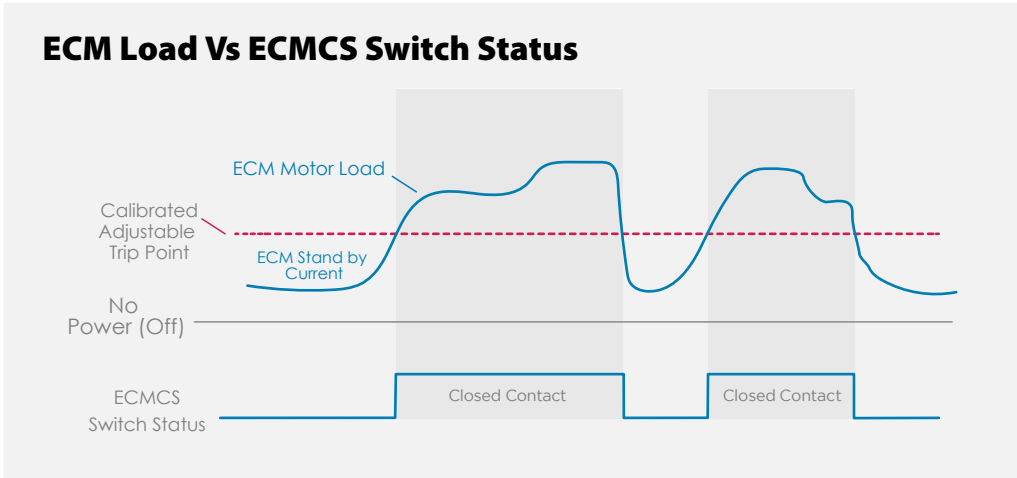

DIMENSIONAL DRAWINGS

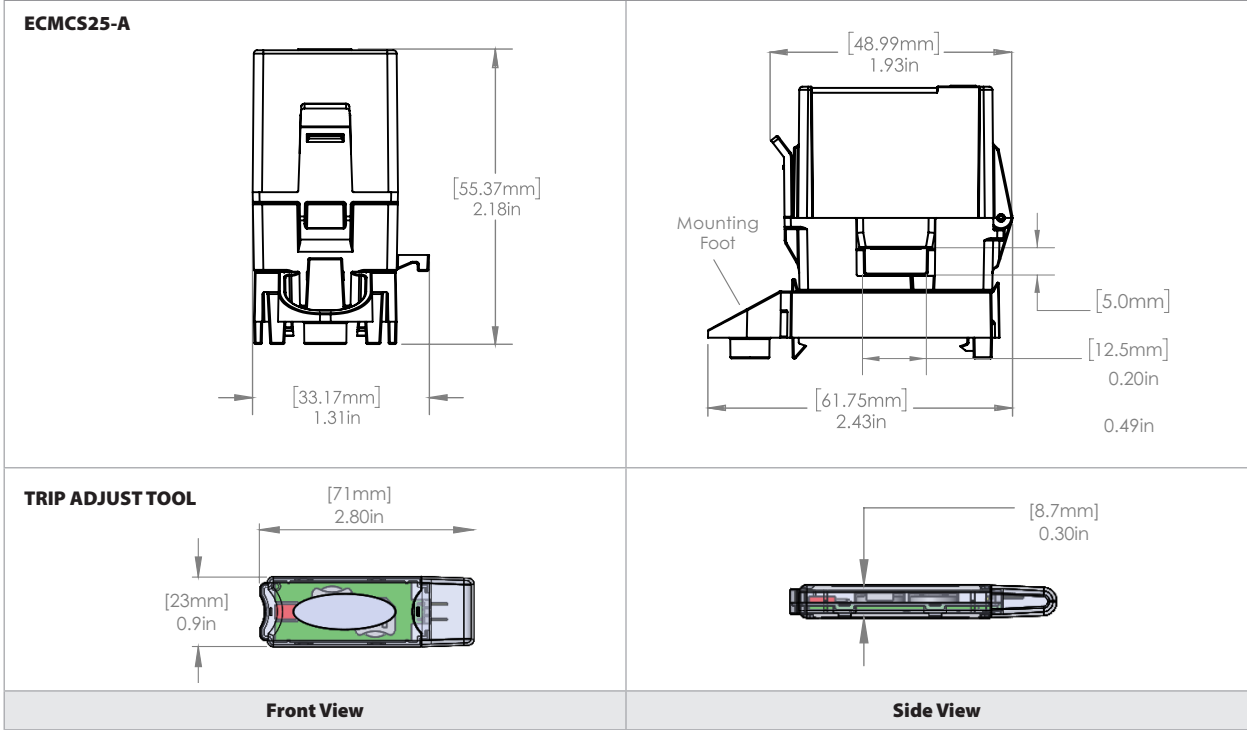

STANDARD ORDERING

Model #	Item #	Trip Point Style	Trip Point	Contact Rating
ECMCS25-A	149979	Adjustable	0.075 to 0.5A	0.1A @ 30 VAC/VDC

Note: The ECM Adjustable Current Switches are not intended to be used in Life / Safety Applications or in Hazardous / Classified locations (environments).

ACCESSORIES ORDERING

Model #	Item #	Description
TRIP ADJUST TOOL	149977	ECM Calibration Tool, Visual Indication of Output Status

